



**INTEX**<sup>®</sup>  
MILLWORK SOLUTIONS



# DARTMOUTH

EXTRUDED RAIL SYSTEM

**INTEX RS35 Dartmouth Rail System Installation Instructions**

Instructional videos are available  
online at [www.intexmillwork.com](http://www.intexmillwork.com)



# Please Read Before Getting Started

## Important Information about the Dartmouth Rail System

The Dartmouth Rail System utilizes pre-marked dimples to assist in locating the balusters for equal spacing. Dimples are used rather than pre-drilled holes to give you the flexibility to use the pre-marked standard locations or to determine your own baluster locations. In addition, an Assembly Jig Kit is available to assist in locating the balusters and positioning them properly for attaching the screws.

Please take note that these pre-marked baluster locations are designed for Post Center to Post Center dimensions of 6', 8', 10', and 12' respectively. If utilizing the pre-marked baluster locations, the maximum rail span will be 4-1/4" less than the post center dimension. For rail spans that are in excess of that dimension you will need to establish your own baluster locations or move up to the next size rail kit to meet spacing code requirements. The quantity of pre-marked dimples allows for either baluster-at-center or space-at-center layout and does not reflect the quantity of balusters included in the kit. **Note: The space between the end baluster and the newel post cannot exceed 4".**

## Dark Paint Caution

If you choose to paint your INTEX Millwork Product, INTEX recommends the use of premium grade latex paints with solar reflective pigment. Preferably paints designed for use with PVC products. Please contact your local paint dealer for professional assistance. Due to the inherent expansion and contraction characteristics of PVC, INTEX PVC millwork products should only be painted colors with an LVR (light reflective value) greater than 55. Use of darker colors may cause damage due to excessive expansion/contraction, and will void the product warranty.

## Cleaning Products for INTEX Millwork Products

Cleaning all INTEX Millwork Products is easy and fast with most major household cleaners. There are many cleaners on the market and the glass cleaners seem to be the best candidate for keeping the finish looking great. The cleaning solution should be applied and immediately wiped dry. As with any cleaning material, the cleaning solution should not be left to stand on the components for an extended period of time.









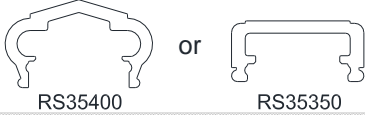

### INTEX recommends the following cleaners:

Windex® 409 Glass and Surface Cleaner®  
Spic & Span Cinch® Fantastik All-Purpose®  
Fantastik Orange Action® Regency® (Glass and Surface)  
Clorox Clean-Up® Glass Plus®  
Fantastik Oxy Power Multi-Purpose Cleaner®

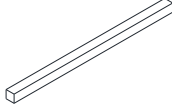
### What to Avoid

Harsh cleaners with glycol ethers or ethanol type solvents and/or isopropyl alcohol are not recommended. Examples of these harmful cleaners are Goof Off®, Walmart "Great Value All Purpose Cleaner®" (glycol ether), 409 General Purpose® (2- Butoxyethanol) and Greased Lightning® (glycol ether), citrus cleaners, abrasive cleaners, and solvents such as acetone, paint remover and lacquer.

## INTEX RS35 Dartmouth Rail System Installation Instructions

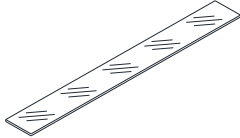
Item		Quantity per Kit			
		6'	8'	10'	12'
Rail Cap		1	1	1	1
Baluster Cap		1	1	1	1
Bottom Rail		1	1	1	1
Upper/Lower Reinforcements		2	2	2	2
Rail Brackets		4	4	4	4
Balusters		12	17	21	26
Crush Block 1-1/4" Square x 4"		1	2	3	4
① Rail Bracket Screws #8 x 1-1/4" Flat Head Square Drive		16	16	16	16
② Rail Attachment Screws #10 X 3" Slot Hex Washer Head		10	10	10	10
③ Baluster Screws #8 x 2-1/2" Flat Head Square Drive		31	44	55	68
④ Baluster Lock Screws #8 x 1-1/2" Flat Head Square Drive		13	18	23	28
Glass Baluster 1/4" x 3-5/8" Tempered 30" or 36" Length (Sold Separately in Packs of 5)		As Required Sold Separately	As Required Sold Separately	As Required Sold Separately	As Required Sold Separately

## INTEX RS35 Dartmouth Rail System Installation Instructions

INTEX has many how-to videos available on our website to assist you in installing Dartmouth Rail in various applications. Please go to [www.intexmillwork.com](http://www.intexmillwork.com) and click on the 'Video Help' link at the top of the page.

**Level Rail Section Application.** (NOTE: for 3-line rail, read Section 5 prior to starting at Section 1)

### 1. Measure to determine baluster layout, cut rail sections to length.

**a.** Ensure newels or columns to which rail will be mounted are plumb and sturdy enough to support rail. If newel/column covers are used, insure they have blocking at each location where railing will be attached.

**b.** Measure span at top and bottom rail locations.

**c.** For standard baluster spacing (with the variable spaces at the ends of each rail section), a re-useable assembly jig kit is available separately (Item # RS35BALJIG.) Alternately the pre-marked locations inside the Baluster Cap and Bottom Rail can be used. Hold the section of the Bottom Rail at the bottom of the posts, and using the pre-marked locations as a reference, determine the best end baluster spacing by either locating a baluster directly at the center of the rail section, or the mid-point between two balusters as the center of the rail section. Once the best end baluster spacing is decided, mark both ends of the rail at the posts and square cut using a miter box. The Baluster Cap and Bottom Rail must be cut with exactly the same spacing, to ensure that the balusters will be plumb. Cut the Rail Top Cap to the required length.

**d.** If equal spacing between all balusters and the posts / columns is desired, disregard section 'c' above and determine spacing based upon width and number of balusters (Note: check local building codes for maximum spacing allowed).

### 2. Drill and assemble rail / baluster section.

**a.** Using the decided upon spacing, at the center of the location for each Baluster, drill a 1/8" hole through the Baluster Cap and Bottom Rail at the centerline.

**b.** Secure each Baluster with one *Baluster Screw* ③ through the Baluster Cap, and one through the Bottom Rail. Ensure Balusters are straight and aligned and secure with one *Baluster Lock Screw* ④ through the Bottom Rail (offset from center) to preclude Baluster from rotating after installation.

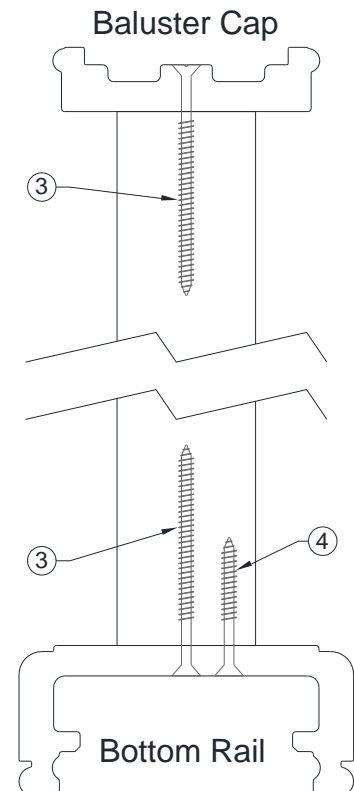



## INTEX RS35 Dartmouth Rail System Installation Instructions

### 3. Prepare aluminum reinforcements.

- a. Cut aluminum rail reinforcements to length, 1/4" shorter than the vinyl rails.
- b. Attach a mounting bracket to both ends of each Aluminum Reinforcement, using four *Rail Bracket Screws* ① supplied. Lubricate the threads with soap to avoid binding or stripping screws.
- c. Locate crush block(s) provided to the bottom Aluminum Reinforcement, with spacing no greater than 36" from the end, or between crush blocks.
- d. Drill a 3/16" hole through the aluminum rail reinforcement, and secure each crush block using one *Baluster Screw* ③.
- e. Drill additional 3/16" holes at each end of aluminum rail reinforcement for drainage.

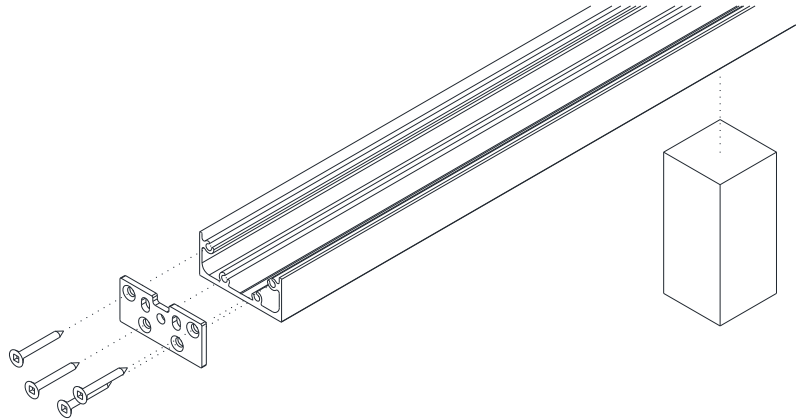

### 4. Install rail

- a. Position bottom Aluminum Reinforcement with crush blocks attached, between newels or columns and centered on face, and secure each end with two Rail Attachment Screws ②.
- b. Position vinyl Rail / Baluster Assembly between newels or columns and seat fully down on bottom aluminum rail reinforcement.
- c. Seat remaining Aluminum Reinforcement into Baluster Cap.
- d. Ensure Top Rail is centered on face of newel or column and secure each end with three Rail Attachment Screws ② supplied.
- e. Drill a 3/16" hole through the aluminum reinforcement over every third baluster (note: offset the hole position to avoid the screw which attaches the baluster to the Baluster Cap) and secure the aluminum reinforcement to the rail/baluster assembly using Baluster Screws ③.
- f. Apply a bead of latex caulk at the contact areas where the Top Cap seats on the baluster cap. Seat the top cap fully onto the baluster cap. **Note: For 10 foot and 12 foot spans, it is necessary to use PVC cement rather than latex caulk to ensure the cap is rigidly affixed under high loads.**

# INTEX RS35 Dartmouth Rail System Installation Instructions

## 5. 3-Line Rail

**a.** Cut all Balusters to height for lower portion of the rail section (24" for 36" finished rail height, 30" for 42" finished rail height). Cut the remaining short pieces of the balusters to 3-7/8". These will be the 'spacer' balusters for the upper portion of the rail section, and can be aligned one over each lower portion Baluster, or other spacing as desired (36" max).

**b.** Follow steps 1 through 4e above to install lower portion of rail section.

**c.** Drill a 3/16" hole down through the aluminum reinforcement and the baluster cap, plumb, at both ends and near the center of the span (between balusters).

**d.** Regardless of rail set top cap style, all Dartmouth 3-Line rail sections use the 3-1/2" style Flat Cap as the cap to the middle rail portion. This rail profile is the same as the Bottom Rail and Flat Cap. Secure the 3-7/8" balusters between this profile and the upper Baluster Cap.

**e.** Place the upper portion down over the baluster cap of the lower portion, and fully seat in place.

**f.** Seat remaining aluminum reinforcement into the baluster cap of the upper portion.

**g.** Ensure rail is centered on face of newel or column and secure each end with three *Rail Attachment Screws* ② supplied.

**h.** Apply a bead of latex caulk at the contact areas where the Top Cap seats on the baluster cap. Seat the top cap fully onto the baluster cap. **Note: For 10 foot and 12 foot spans, it is necessary to use PVC cement rather than latex caulk to ensure the cap is rigidly affixed under high loads.**

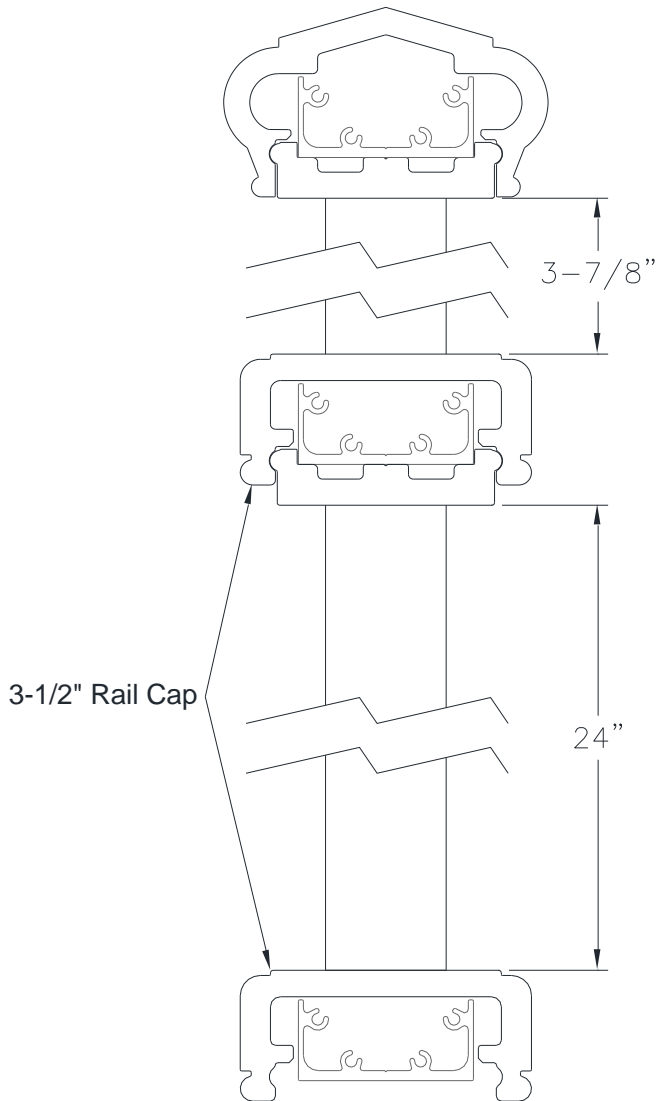

## **Level Rail Section Application with Glass Balusters.**

*Note: Glass Baluster application requires the RS35 Dartmouth series rail sets specifically prepared for the Glass Balusters, along with the appropriate quantities of balusters (sold separately in packs of 5).*

### **1. Measure to determine baluster layout, cut rail sections to length.**

- a.** Ensure newels or columns to which rail will be mounted are plumb and sturdy enough to support rail. If newel/column covers are used, ensure they have blocking at each location where railing will be attached.
- b.** Measure span at top and bottom rail locations.
- c.** The slots for the Glass Balusters are set for standard baluster spacing (with the variable spaces at the ends of each rail section. Hold the Bottom Rail at the bottom of the newels, and using the pre-marked locations as a reference, determine the best end baluster spacing by either locating a baluster directly at the center of the rail section, or the mid-point between two balusters as the center of the rail section. Once the best end baluster spacing is decided, mark both ends of the rail at the newels and square cut using a miter box. The Baluster Cap and Bottom Rail must be cut with exactly the same spacing, to ensure that the balusters will be plumb. Cut the Rail Top Cap to the required length.

### **2. Prepare aluminum reinforcements.**

- a.** Cut the aluminum rail reinforcements to length, 1/4" shorter than the PVC rails.
- b.** Attach mounting brackets to both ends of the upper aluminum rail reinforcement, using four *Rail Bracket Screws* ① supplied. Lubricate the threads with soap to avoid binding or stripping screws.
- c.** Locate crush block(s) provided to the bottom Aluminum Rail Reinforcement, with spacing no greater than 36" from the end, or between Crush Blocks.
- d.** Drill a 3/16" hole through the Aluminum Rail Reinforcement, and secure each crush block using one *Baluster Screw* ③.
- e.** Drill one additional 3/16" hole at each end of the bottom Aluminum Rail Reinforcement for drainage.

### **3. Install rail**

- a.** Position bottom Aluminum Rail Reinforcement, with crush block(s) attached, between newels or columns, centered in newel or column face, and secure each end with two *Rail Attachment Screws* ② supplied.
- b.** Position the Bottom Rail between newels or columns and seat fully down on bottom aluminum rail reinforcement.

## INTEX RS35 Dartmouth Rail System Installation Instructions

- c. Place a Tempered Glass Baluster into each slot.
- d. Position the Baluster Cap over the ends of the Glass Balusters.
- e. Seat remaining aluminum reinforcement into the Baluster Cap.
- f. Ensure rail is centered on face of newel or column and secure each end with two #12, 4" Long Attachment Screws (included.)
- g. Drill a 3/16" hole down through the Aluminum Reinforcement and the Baluster Cap centered over every third space (the gap between the Glass Balusters.) Use care to center the holes directly between the Glass Balusters, as there are existing screws in the Baluster Cap Assembly that may cause interference.
- h. Secure the Aluminum Reinforcement to the Baluster Cap using *Baluster Lock Screws* (4).
- i. Apply a bead of latex caulk at the contact areas where the Top Cap seats on the Baluster Cap. Seat the Top Cap fully onto the Baluster Cap.

### Stair/Rake Rail Installation Instructions

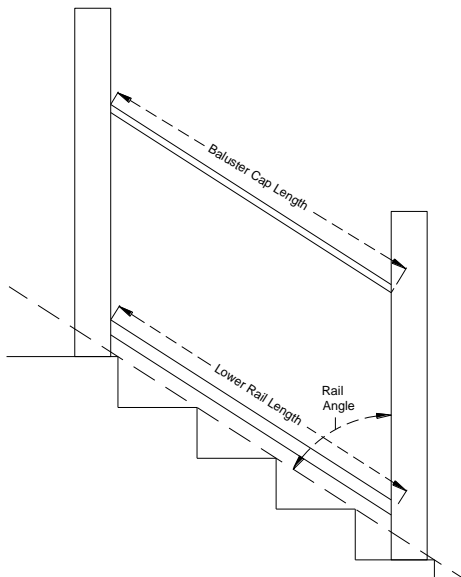

*Note: IBC code requires that finished stair rail heights be a minimum of 34" plumb off the nose of the tread. The standard RS35 36" rail kit's balusters will typically meet these requirements provided the rail is being installed with the bottom rail elevated above the stair treads. In the event that the railing is being installed directly at or slightly above the stair tread nose, INTEX recommends using the RS35 Stair/Rake Rail kit, which will meet the minimum height requirement any scenario.*

#### **1. Determine angle, measure and cut rail sections to length.**

a. Ensure newels or columns to which rail will be mounted are plumb and sturdy enough to support rail. If newel/column covers are used, insure they have blocking at each location where railing will be attached.

b. Determine and mark angle

c. Determine location and cut Lower Rail and Baluster Cap to required length.



# INTEX RS35 Dartmouth Rail System Installation Instructions

## 2. Determine baluster layout and assemble rail/baluster section.

- a. Trim Balusters to desired length and angle.
- b. For standard baluster spacing (with the variable spaces at the ends of each rail section), use the pre-marked locations inside the Baluster Cap and Bottom Rail. Determine best end spacing by either locating a Baluster directly at the center of the rail section or the midpoint between two Balusters as the center of the rail section. Once Baluster spacing is determined, cut end(s) of Baluster Cap and Bottom Rail to angle and length. Note: Do not cut Rail Top Cap until section is assembled and secured at all four mounting points.
- c. If equal spacing between all balusters and newels/columns is desired, disregard section 'a' above and determine spacing based upon width and number of balusters (Note: check local building codes for maximum spacing allowed).
- d. Secure each Baluster with one *Baluster Screw* ③ through the baluster cap, and one through the bottom rail. Insure balusters are straight and aligned and secure with one *Baluster Lock Screw* ④ through the bottom rail (offset from center) to preclude baluster from rotating after installation.

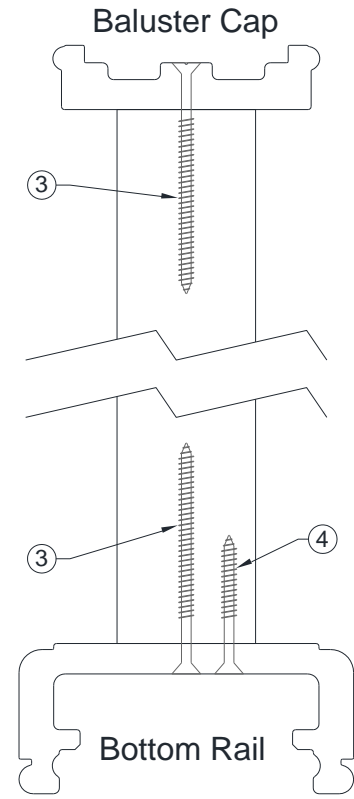

## 3. Prepare aluminum reinforcements.

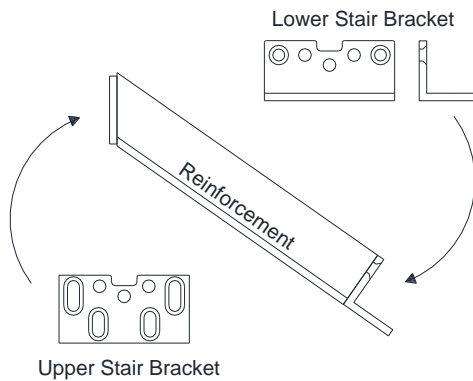

- a. Attach a lower stair bracket (90-degree bend) using two *Rail Bracket Screws* ① supplied to the lower end of each reinforcement. Lubricate the threads with soap to avoid binding or stripping screws Note: Do not cut this end of the reinforcement to the rail angle.
- b. Measure and cut the upper end of both reinforcements to the rail angle determined in Step 1, **including the protruding portion of the lower bracket as part of the total length**. Attach an Upper Stair Bracket to the angle cut end of the top Aluminum Reinforcement, with the Bracket flush with the top of the Reinforcement, using four *Rail Bracket Screws* ① supplied. Attach an Upper Stair Bracket to the angle cut end of the bottom rail reinforcement, with the bracket flush with the bottom of the reinforcement, using four *Rail Bracket Screws* ① supplied. Lubricate the threads with soap to avoid binding or stripping screws.
- c. Cut one end of crush block to angle of rail and locate to the Bottom Aluminum Reinforcement, with spacing no greater than 32" from the end, or between crush blocks. Ensure that crush block(s) will be located on a stair tread.
- d. Drill a 3/16" hole through the aluminum rail reinforcement, and secure each crush block using one Baluster Screw ③.

## INTEX RS35 Dartmouth Rail System Installation Instructions

### 4. Install rail

- a. Position Bottom Aluminum Reinforcement, with crush block(s) attached, between newels or columns, centered in newel or column face, and secure each end with two *Rail Attachment Screws* ② supplied.
- b. Position vinyl rail/baluster assembly between newels or columns and seat fully down on bottom aluminum rail reinforcement.
- c. Seat remaining Aluminum Reinforcement into Baluster Cap.
- d. Ensure rail is centered on face of newel or column and secure each end with three *Rail Attachment Screws* ② supplied.
- e. Drill a 3/16" hole through the aluminum reinforcement over every third baluster (note: offset the hole position to avoid the screw which is into the top of each baluster) and secure the aluminum reinforcement to the rail/baluster assembly using *Baluster Screws* ③ supplied.
- f. Apply a bead of latex caulk at the contact areas where the Top Cap seats on the Baluster Cap. Seat the Top Cap fully onto the Baluster Cap.

# INTEX RS35 Dartmouth Rail System Installation Instructions

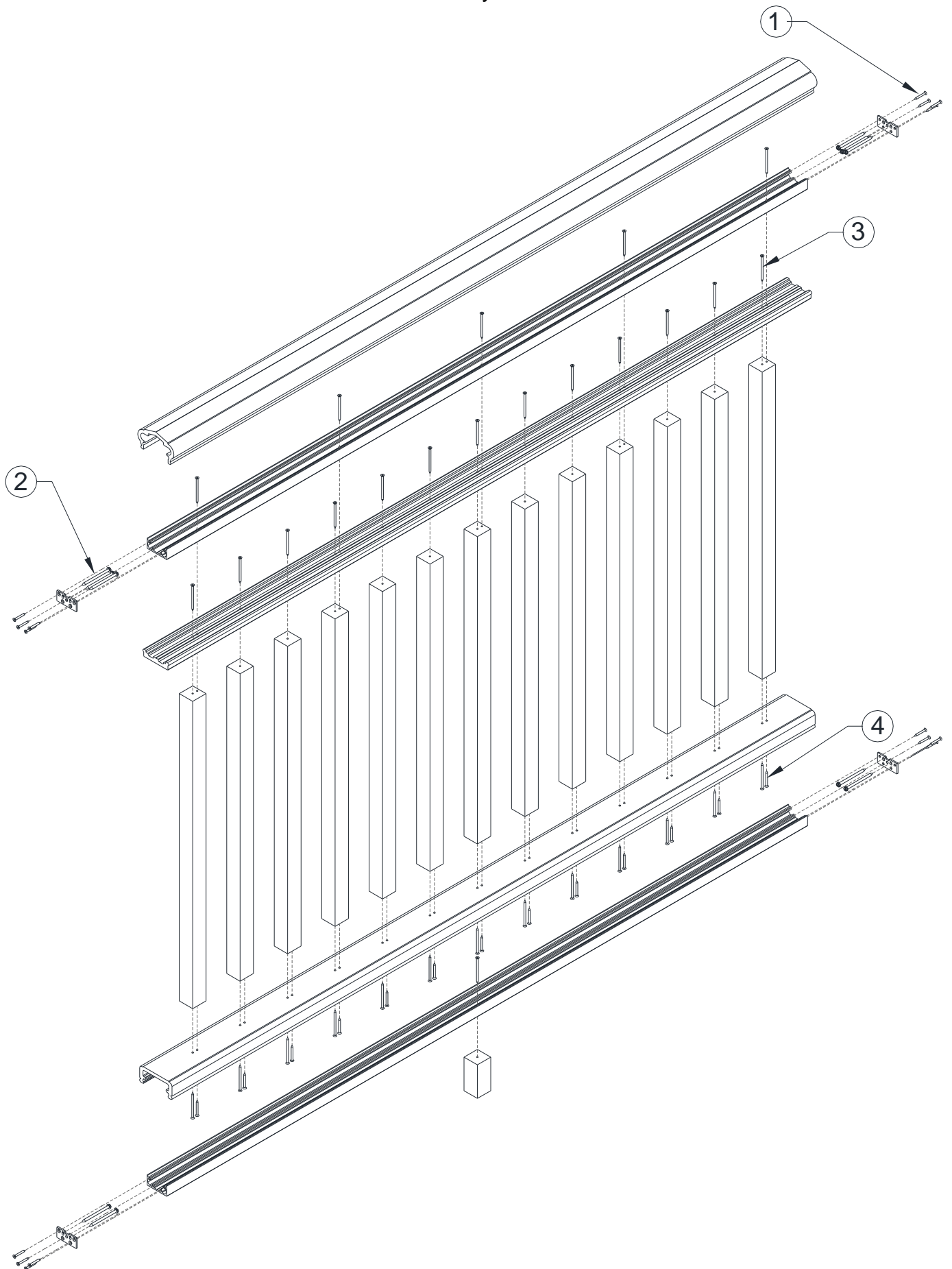

*Fine craftsmanship designed to  
compliment your home and budget*

Nothing adds distinction and definition to homes and outdoor living spaces like a stylish exterior railing. INTEX Millwork Solutions railings come in a variety of shapes and styles to compliment any architecture and budget.

## **LIBERTY** EXTRUDED RAIL SYSTEM

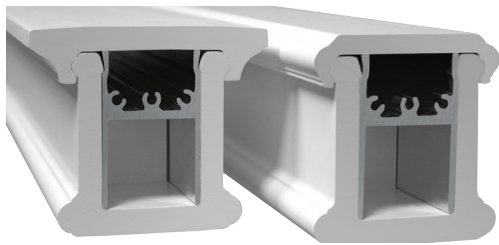

## **HAMPTON** EXTRUDED RAIL SYSTEM

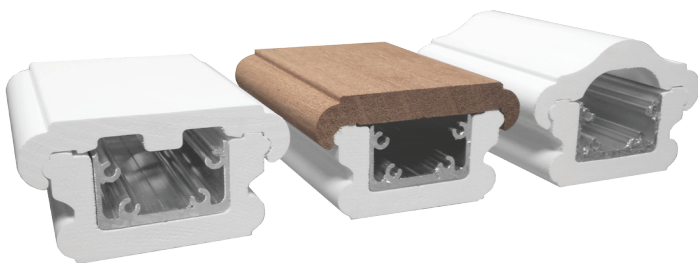

## **NAUTILUS** MILLED RAIL SYSTEM

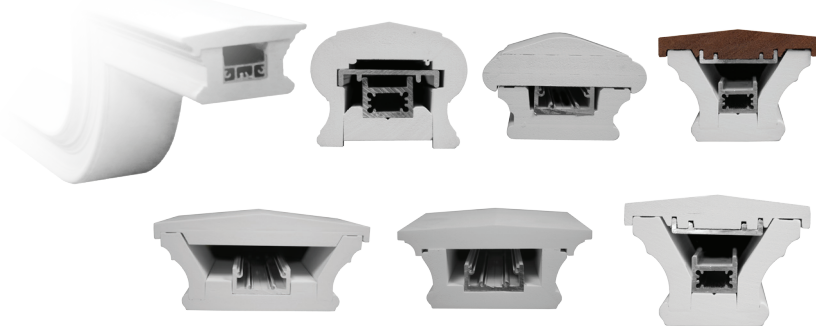

Railing Systems | Newel & Column Wraps | Pergola Systems | Window Surrounds | Mouldings & Trim | Entry Systems | Gutter Systems



*The finishing touch that stands the test of time.*